

RECON 1500

Tube Leak Test Gun - Vacuum



Tube & Pipe Cleaners ◦ Tube Testers ◦ Tube Plugs ◦ Tube Removal ◦ Tube Installation



Operating and Maintenance Instructions

TABLE OF CONTENTS

Introduction 4

Safety Guidelines 5

General Information..... 6

Operation Instructions..... 8

Seal Sets & Support Tubes 9

Parts List & Diagrams..... 10

Maintenance Instructions 14

Warranty 15

INTRODUCTION

Thank you for purchasing this Elliott product. More than 100 years of experience have been employed in the design and manufacture of this control, representing the highest standard of quality, value and durability. Elliott tools have proven themselves in thousands of hours of trouble-free field operation.

If this is your first Elliott purchase, welcome to our company; our products are our ambassadors. If this is a repeat purchase, you can rest assured that the same value you have received in the past will continue with all of your purchases, now and in the future.

The RECON 1500 Tube Leak Test Gun has been designed for the following types of equipment:

Heat Exchangers

Condensers

Chillers

Evaporators

Air Conditioners

If you have any questions regarding this product, manual or operating instructions, please call Elliott at +1 800 332 0447 toll free (USA only) or +1 937 253 6133, or fax us at +1 937 253 9189 for immediate service.

SAFETY GUIDELINES

Read and save all instructions. Before use, be sure everyone using this tool reads and understands this manual, as well as any labels packaged with or attached to the machine.

CAUTION

Operators should always wear safety glasses, hearing protection and a face shield when operating this tool.

- Operators should always wear safety glasses and a face shield when operating this tool.
- This device is capable of producing continuous noise levels reaching 105 dBa. Operators should always wear hearing protection when operating this equipment.
- Operator responsible for supplying approved lubricated air for operation.
- Prior to testing, the tubes should be cleaned and any loose deposits or scale should be removed. If the tubes have not been cleaned any foreign materials present may be ejected during the testing operation and may damage the test guns or injure the operators.
- Use Proper Accessories. Use Elliott accessories only. Be sure accessories are properly installed and maintained.
- Maintain Labels and Nameplates. These carry important information and will assist you in ordering spare and replacement parts. If unreadable or missing, contact an Elliott service facility for a replacement.

GENERAL INFORMATION

RECON Series 1500 (TTV1500) Kit Includes:

Tube Leak Test Gun – Vacuum

T-Handle Plugging Tool

Support Tube Assemblies (TTVST1, TTVST2*)

Toolbox

*Arrives pre-assembled with TTVST2

Start-Up

If the tubes have been chemically cleaned, please check with Elliott Tool regarding the compatibility of the test gun seals with the cleaning agent.

Range	Support Tube Assembly Part Number
0.28" - 0.69" (7.1 mm - 17.5 mm)	TTVST1
0.64" - 1.45" (16.3 mm - 36.8 mm)	TTVST2
1.490" - 2.456" (37.8 mm - 62.4 mm)	TTVST3*
<i>*TTVST3 must be ordered separately.</i>	

Make sure the seal and support tube assembly are the correct size for the tubes being tested. For tubes with IDs larger than 2.456" (62.4mm), please contact the factory. Using seals that are improperly sized may cause inability to pull a vacuum on tube end.

GENERAL INFORMATION

Configuring Support Tube and Seal Assemblies:

1. Confirm that the correct assembly is chosen. Apply Teflon Tape to the NPT threads of both support tubes. Firmly thread one support tube into the open NPT port of the filter on the RECON 1500 Test Gun. Tighten the lock nut onto the front end of support tube to remove any slack in the assembly.
2. Firmly thread the second support tube into the NPT port of the T-Handle Plugging Tool.
3. Assembly order is shown below.

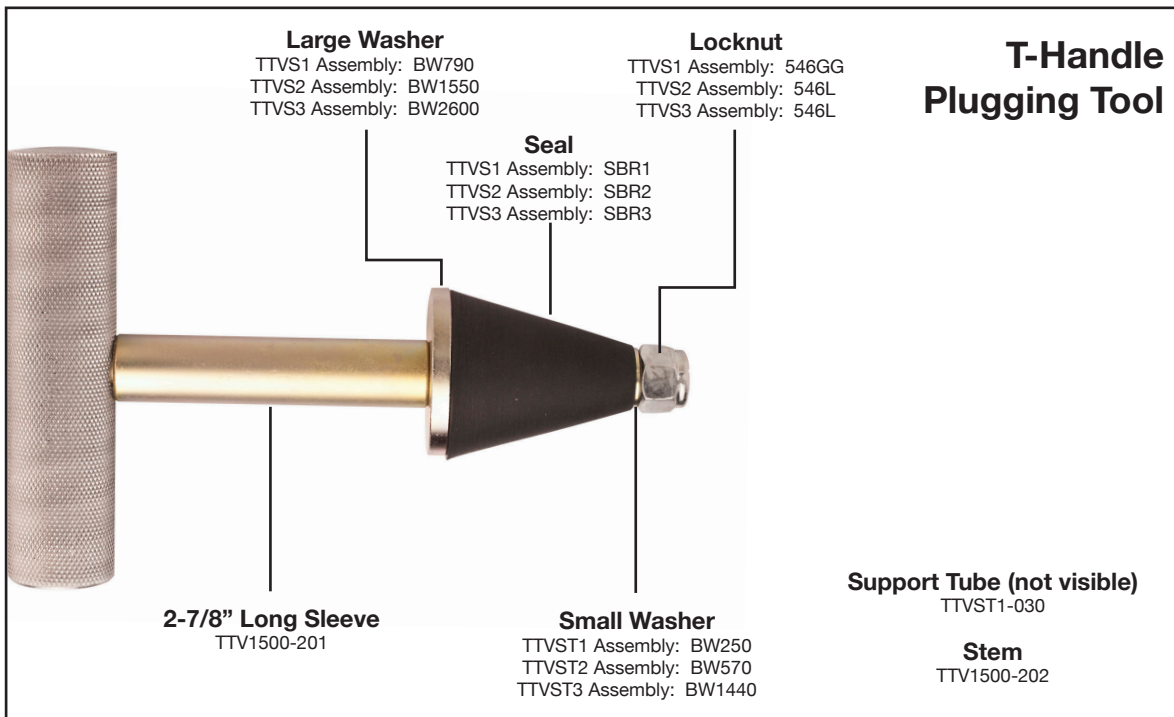
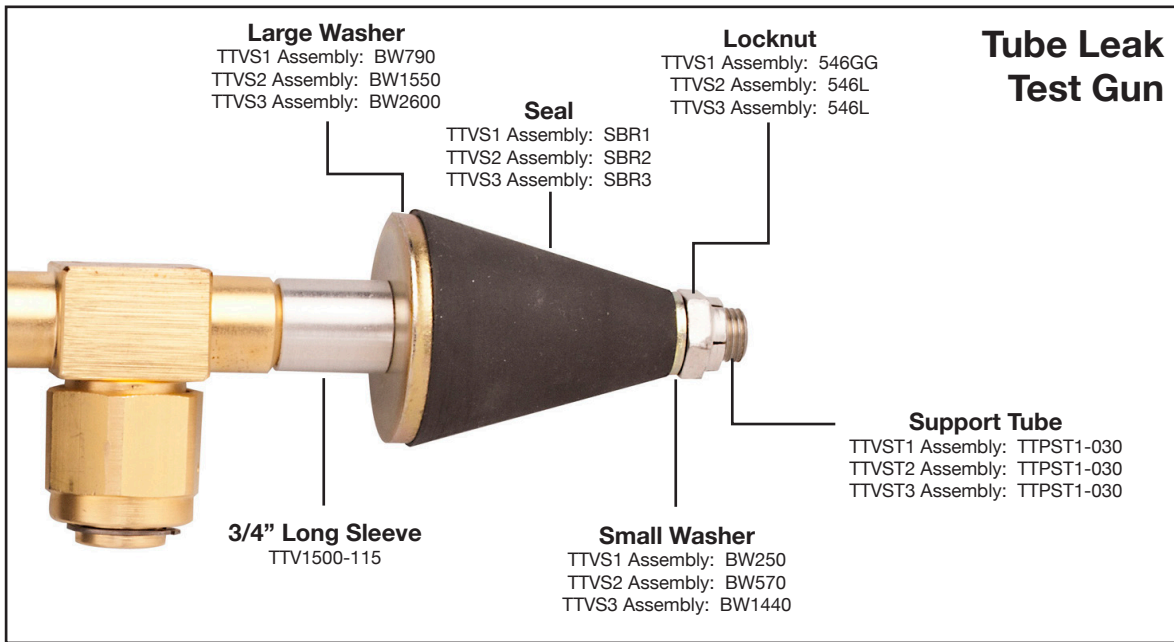

OPERATION INSTRUCTIONS

1. Attach air supply to the 1/4 quick disconnect nipple of the RECON 1500 Test Gun. The RECON 1500 Test Gun will be operational on plant air supplies ranging from 40 to 130 psi (2.7 to 8.9 Bar) at a minimum of 5 cfm (2.4 lps).
2. Insert the tapered seal of the gun into one end of the tube for a snug fit to create a leak tight seal. The support tube of the RECON 1500 should be in-line with the tube being tested at all times. Insert the tapered seal of the T-Handle Plugging Tool into the other end of tube for a snug fit to create a leak tight seal.
3. Begin testing: Depress the lever on the RECON 1500 Test Gun to begin evacuating air from the tube until the vacuum gauge needle stops moving. Release the lever while maintaining a leak tight seal on the tube end. Gun operators should observe the vacuum gauge on the gun. Any tube leaks will be identified by a reduction in vacuum reading on the gauge.
4. If no leaks are detected, remove the RECON 1500 Test Gun & T-Handle Plugging Tool from the tube ends by pulling the RECON 1500 Test Gun & T-Handle Plugging Tool straight out of the tube. Reinsert them into the next respective tube ends to be tested. NOTE: The total operation should be completed in 15 to 30 seconds. Your actual testing time will depend on the amount of time you choose to hold the vacuum test and the length of the tubes.
5. Repeat steps 5 through 6 until testing is complete.

SEAL SETS & SUPPORT TUBES

Tube ID Range	Tube Leak Test Gun Kit	Seal & Washer Set Part Number
0.280"-0.690" (7.1-17.5mm)	TTV1500	TTVS1
0.640"-1.450" (16.2-36.8mm)		TTVS2
1.490"-2.456" (37.8-62.4mm)		TTVS3

Support Tube Extensions				
Tube ID Range	12" (305mm) Part #	24" (610mm) Part #	36" (914mm) Part #	48" (1,219mm) Part #
0.280"-0.690" (7.1-17.5mm)	TTVST1-12	TTVST1-24	TTVST1-36	TTVST1-48
0.640"-1.450" (16.2-36.8mm)	TTVST2-12	TTVST2-24	TTVST2-36	TTVST2-48

TUBE LEAK TEST GUN - VACUUM

TTV1500-100

ITEM NO.	PART NAME	NO. REQ	PART NUMBER
1	LOCK NUT	5	TTP1250-172
2	LABEL	1	ETTLBL1800A
3	VACUUM GAUGE	1	TTV1500-190
4	PIPE FITTING	1	41-50785K219
5	SLEEVE	1	TTV1500-115
6	FILTER	1	TTV1500-177
7	LEVER	1	TTP1250-160
8	SPRING PIN, 3/32 X 7/8	1	P8381-14
9	HANDLE HALF	1	TTV1500-152
10	1/4 NIPPLE	1	41-6534K18
11	CHECK VALVE	1	TTP1250-175
12	ELBOW	2	41-50785K81
13	BUTTON VALVE	1	TTP1250-176
14	HANDLE HALF	1	TTV1500-153
15	VENTURI FUNNEL	1	TTV1500-128
16	CUP POINT SET SCREW, #10-32 X 1/4	1	128P
17	VENTURI NOZZLE	1	TTV1500-125
18	LONG NIPPLE	1	TTP1250-181
19	LONG NIPPLE	1	TTP1250-182
20	BUTTON HEAD CAP SCREW	5	TTP1250-173
21	LABEL (NOT SHOWN)	1	TTV1500LBL-1
22	SUPPORT TUBE ASSEMBLY	1	TTVST2

TUBE LEAK TEST GUN - VACUUM

TTV1500-100

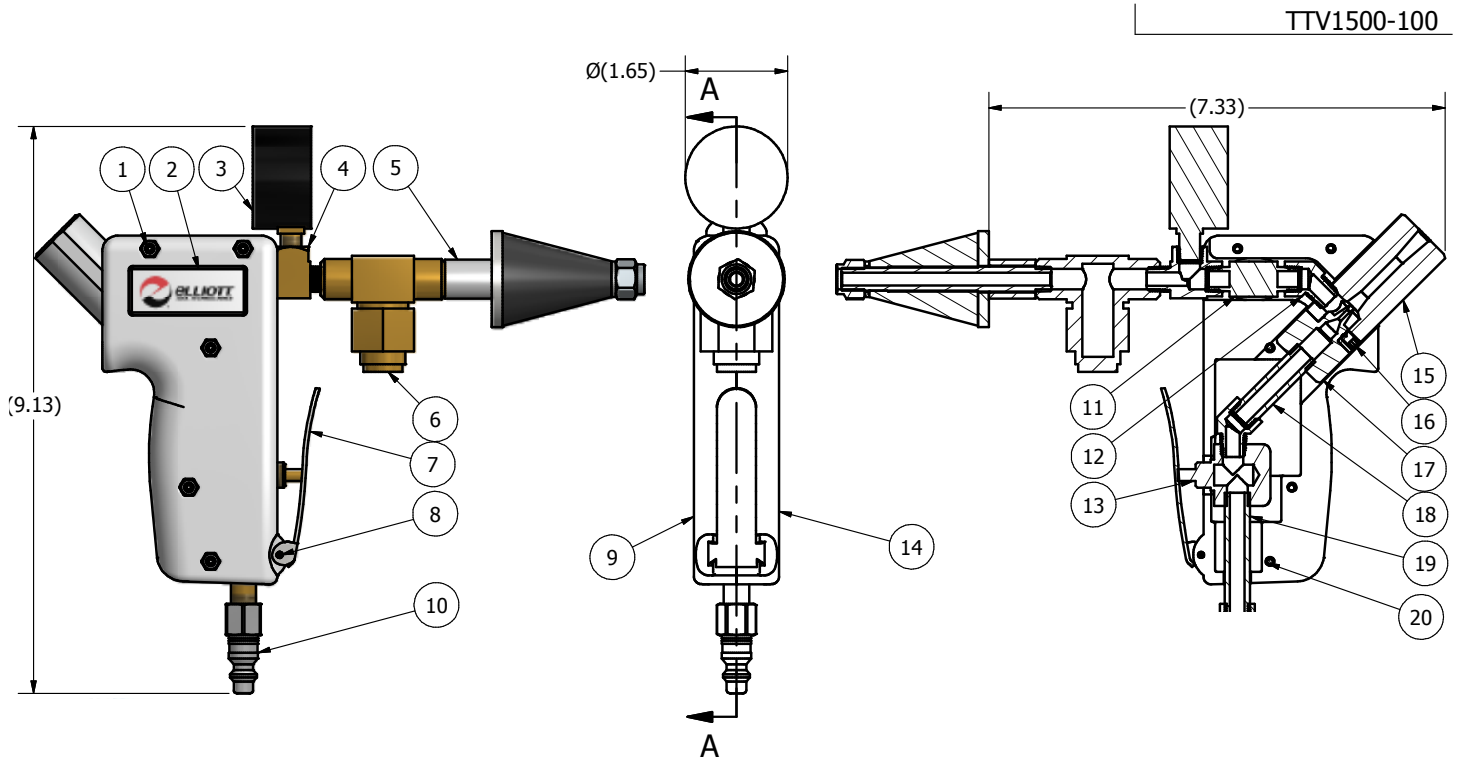

TUBE LEAK TEST GUN - VACUUM

TTV1500-200

ITEM #	PART NAME	NO. REQ	PART NUMBER
1	HANDLE GRIP	1	TTV1500-203
2	SLEEVE	1	TTV1500-201
3	BACKUP WASHER	1	BW1550
4	VACUUM SEAL	1	SBR2
5	BACKUP WASHER	1	BW570
6	ELASTIC LOCKNUT, 3/8-24	1	546L
7	STEM	1	TTV1500-202

TUBE LEAK TEST GUN - VACUUM

TTV1500-200

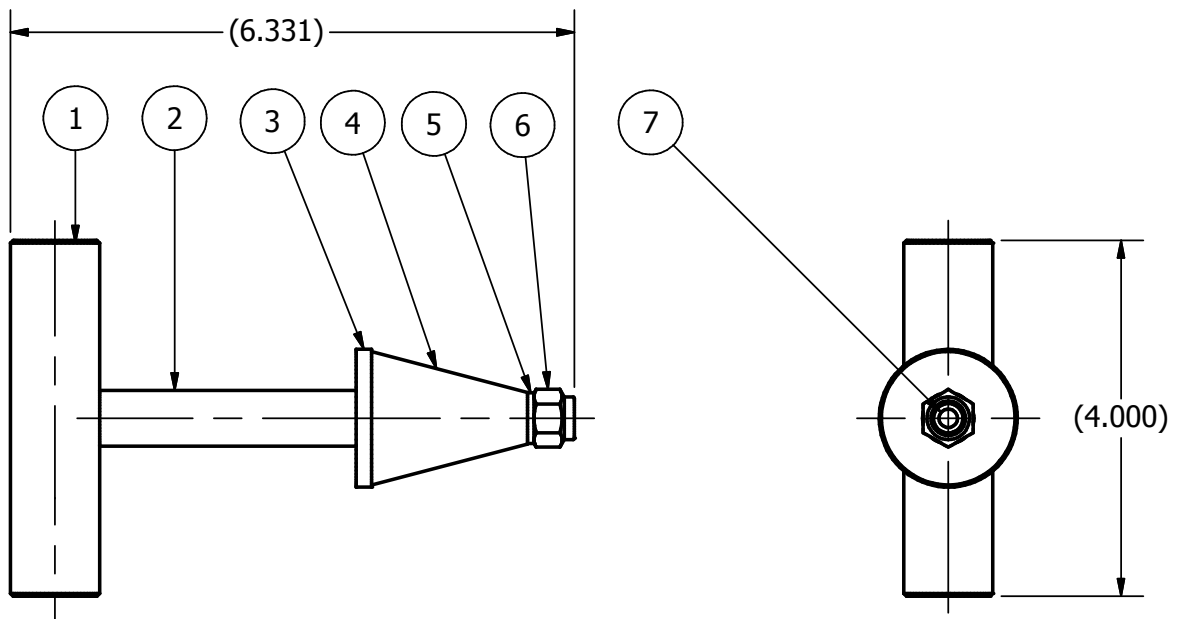
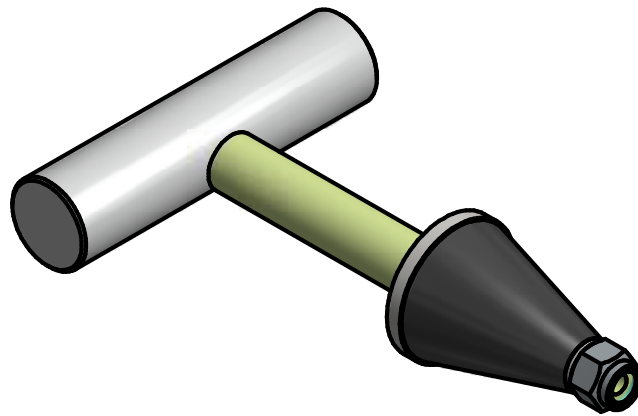

MAINTENANCE INSTRUCTIONS

The proper performance and service life of every machine depends on how well it is maintained. The following should become a regular routine of operations.

1. Replacing the Air Filter Element:

- a.) Remove the snap ring and unscrew the hex nut at the bottom of the filter body.
- b.) Pull out the filter strainer element from filter body with needle nose pliers.
- c.) Insert new element open end first, until snug.
- d.) Screw hex nut back onto the filter body and replace snap ring.

WARRANTY

Should any part, of Seller's own manufacture, prove to have been defective in material or workmanship when shipped (as determined by Seller), Seller warrants that it will, at its sole option, repair or replace said part f.o.b., point of manufacture, provided that Buyer notifies, in writing, of such defect within twelve (12) months from date of shipment from the manufacturing plant.

On request of Seller, the part claimed to be defective will be returned, transportation, insurance, taxes and duties prepaid, to the factory where made, for inspection. Any item, which has been purchased by Seller, is warranted only to the extent of the original manufacturer's warranty to Seller. Seller shall not be liable for any damages or delays caused by defective material or workmanship.

No allowance will be made for repairs or alterations made by others without Seller's written consent or approval. If repairs or alterations are attempted without Seller's consent, Seller's warranty is void.

THE WARRANTIES PROVIDED IN THE OBLIGATIONS AND LIABILITIES OF SELLER HEREUNDER, AND THE RIGHTS AND REMEDIES OF BUYER HEREUNDER ARE EXCLUSIVE AND IN SUBSTITUTION FOR, AND BUYER HEREBY WAIVES ALL OTHER WARRANTIES, GUARANTEES, OBLIGATIONS, CLAIMS FOR LIABILITIES, RIGHTS AND REMEDIES, EXPRESS OR IMPLIED, ARISING BY LAW OR OTHERWISE, INCLUDING BUT NOT LIMITED TO THE IMPLIED WARRANTY FOR MERCHANTABILITY AND FITNESS FOR PURPOSE.

Seller's total liability is limited to the lower of the cost of repair or replacement.



Contact Us

Elliott Tool offers a complete line of precision tube tools to meet your needs. Contact us or your local support.

Elliott Tool Technologies, Ltd.
1760 Tuttle Avenue
Dayton, Ohio 45403-3428
Phone: +1 937 253 6133 • +1 800 332 0447
Fax: +1 937 253 9189
www.elliott-tool.com

Printed in the USA
©09/2022 Elliott Tool Technologies, Ltd.
TM-114
PL-102

Locally Supported By:

www.elliott-tool.com/support